



**3 GHz SMA LATCHING S.P.4 T. SWITCH**

OPTIONS : INDICATOR /SELF CUT-OFF /AUTO RESET / TTL DRIVE /SUPP.DIODES

**R F CHARACTERISTICS**

NUMBER OF WAYS : 4  
FREQUENCY RANGE : 0 - 3 GHz  
IMPEDANCE : 50 Ohms

FREQUENCY (GHz)	0 - 3
V.S.W.R	<= 1.20
INSERT. LOSS <=	0.20 dB
ISOLATION >=	80 dB
AVER. POWER (*)	240 W

**ELECTRICAL CHARACTERISTICS**

ACTUATOR : LATCHING  
NOMINAL CURRENT AT 25° C (+10%) : 250 mA  
ACTUATOR VOLTAGE (V<sub>CC</sub>) : 28V (24 to 30V) / NEGATIVE COMMON  
TERMINALS : 25 pins D-SUB male connector  
INDICATOR RATING : 1 W / 30 V / 100 mA  
SELF CUT-OFF TIME : 40 ms < CT < 120 ms  
TTL INPUTS (E) - High level : 2.2 to 5.5V / 800µA at 5V  
- Low level : 0 to 0.8V / 20µA at 0.8V

**MECHANICAL CHARACTERISTICS**

CONNECTORS : SMA female per MIL C 39012  
LIFE : 5.000.000 cycles per position  
SWITCHING TIME (nominal voltage;25° C) : < 40 ms  
CONSTRUCTION : splashproof  
WEIGHT : < 220 g

**ENVIRONMENTAL CHARACTERISTICS**

OPERATING TEMPERATURE RANGE (°C) : -40 , +85  
STORAGE TEMPERATURE RANGE (°C) : -55 , +85

(\* : average power at 25° C per RF path)

This information is given as an indication. In the continual goal to improve our products, we reserve the right to make any modifications judged necessary

**DRAWING**

General tolerance: ± 0,5 mm

**R573 393 425**

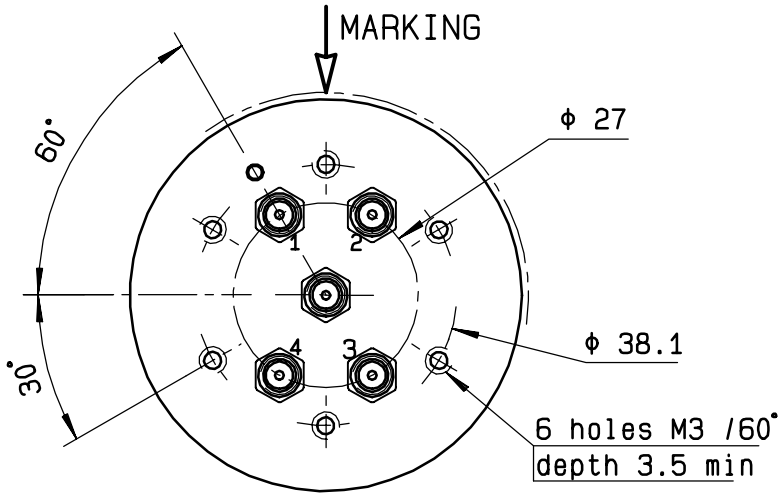

TTL input	RF continuity	Ind.
E1 = 1	IN ↔ 1	D.E
E2 = 1	IN ↔ 2	D.F
E3 = 1	IN ↔ 3	D.G
E4 = 1	IN ↔ 4	D.H

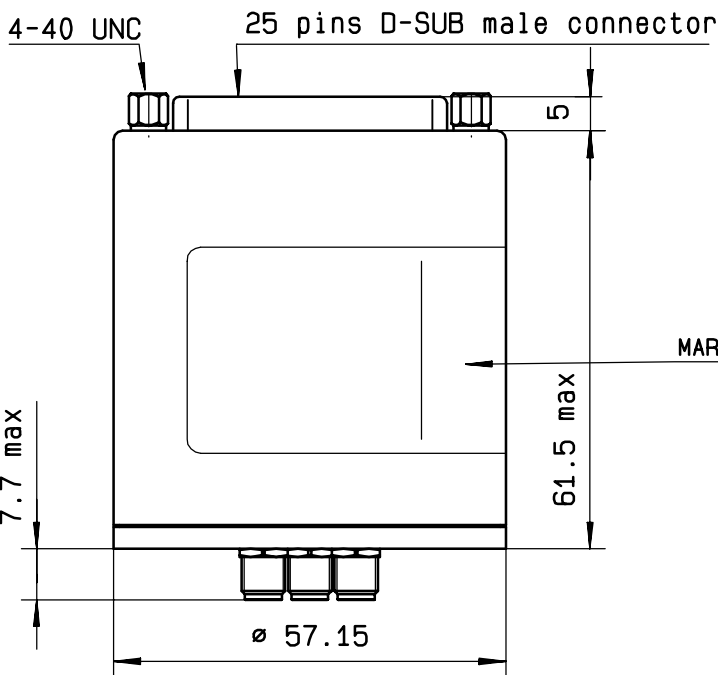

MARKING TOP VIEW (TERMINALS)

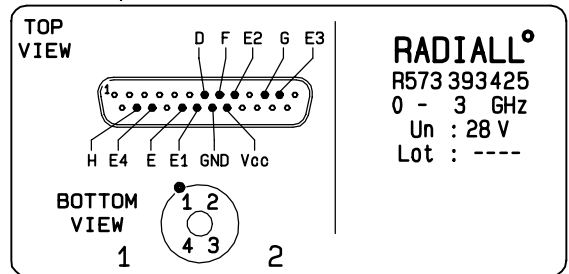

**RADIALL**<sup>®</sup>  
R573 393 425  
0 - 3 GHz  
Un : 28 V  
Lot : ----

**SCHEMATIC DIAGRAM**

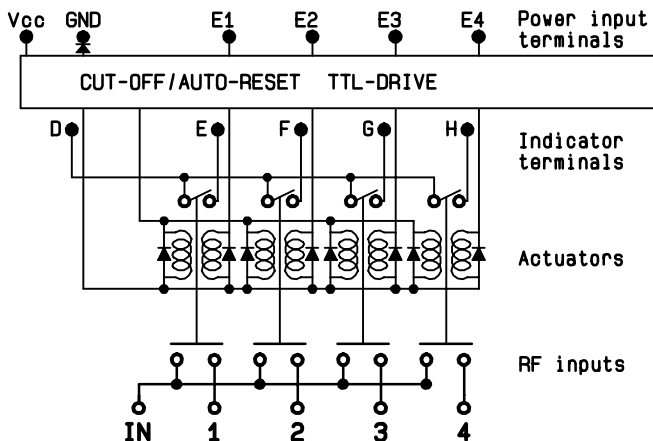

This information is given as an indication. In the continual goal to improve our products, we reserve the right to make any modifications judged necessary

4113-9212